



MAYUR

ENGINEERING AND AUTOMATION



OUR SERVICES
Annual Maintenance Contract
E.O.T. Crane, Lift's, Gate, Automatic Shutter, S.P.M. etc.



EOT Crane Manufacturer / Electric Overhead Travelling crane



Cranes are rugged in construction and find their use in a wide range of hoisting capacities and applications.

EOT crane find their application in power plant, workshop duty, transformer industry, cable industry, process plants, steel plants, coal fields, cement plants, engineering industry to just name a few.

Heavy duty barrel winch type of double girder cranes are designed and manufactured to customer's precise needs.

Type off crane - Single girder EOT crane, Double girder crane, Jib crane, Goliath crane etc.

Special Features of Barrel Winch Cranes :

- Capacity up to 250 MT
- Barrel Winch construction with True Vertical Lift
- Robust construction suitable for heavy duty application
- Alloy Steel, hardened, precision cut gears
- Foot mounted type fabricated gearbox casing horizontally split at centre line for ease of maintenance for hoist
- Foot mounted hydraulic thruster brakes for hoist
- Lift and speeds to suit your specific application
- Ample space on trolley for ease of maintenance
- L Type housing for Long travel wheels
- Full length (along the crane span) platform on the Long travel drive side girder
- All motors are TEFC with class F insulation
- VVVF drives are available as an option
- Option for Pendent, Radio Remote and Cabin Operation



Gates >> Sliding Gates

Conventional Sliding Gates are gates which use a ground mounted track for the gate wheels to move on. Tracked sliding gates can span larger opening widths. Optionally a pedestrian gate can be integrated with these type of gates or a separate pedestrian gate can be built.

- Designed and fabricated with special square or rectangular hollow sections, along with MS sheets and flats assembled by high quality welding
- Gates are aesthetically pleasing and the pre-tensioning of the gate leaf construction reduces the risk of bending.

- Wide range of models for gates weighing from 300 kg to 1800 kg
- Manual operation in case of power failure
- Highly compact dimensions & extremely silent operation. Built-in anti jerk device prevents damage to the automatic system
- Startup at maximum power permits the motor to overcome any initial friction caused by ice, dust, etc. Motor protected by an internal thermal switch
- Obstacle detection causes the gate movement to stop if an obstacle is detected
- The advance electronic control unit permits operation time adjustment, partial opening, automatic closing, step by step control, stop safety, reverse safety etc



Rolling Shutters & Remot Control Rolling Shutters

Rolling Shutters - Classic, are ideal for situations where side room is at a premium and security is required. Our Rolling Shutters require very little headroom above the structural opening. They combine strength with elegance along with durability and are designed for both external and internal applications. Rolling Shutters are fabricated of interlocked Galvalume, Galvanized Insulated and Non Insulated, Stainless Steel, Patented Aluminum or Polycarbonate profiles and patented Bright Steel Bar Rolling Grills. Each of our Rolling Shutters is solidly constructed to promote trouble-free operation and long life.

All our Rolling Shutters are automated using robust drive technology with manual override in case of power failure and is compact, noiseless, reliable with low decibel level.

Rolling Shutters fit openings to a maximum width of 3,000 mm and height of 30,000 mm with an endless array of options to satisfy both aesthetic considerations as well as working requirement.



Bright Steel Bar Rolling Grills

Honeycomb design of Rolling Grills provides attractive yet functional means to secure areas where public access must be restricted. Honeycomb Rolling Grills constructed of Bright Steel Bar are attractively patterned and are ideal for display windows of showrooms, shopping malls and perfectly match with any building's architecture and interior space. Rolling Grills provide optimal protection without sacrificing visual access, air circulation or light infiltration.



Commercial Doors » Sliding Doors

Automatic Sliding Doors are solutions devised to meet the modern requirements of interior design. They smartly enhance the look of commercial areas and work environments. These are ideal for office buildings, shopping malls, apartments, hotels, restaurants, conferences and others. **MAYUR** offers a complete range of automatic systems for sliding pedestrian doors (single leaf, double leaf, telescopic) curved doors



- A complete range of automatic systems for sliding pedestrian doors (single leaf, double leaf, telescopic) curved doors and revolving doors are available
- Maximum clear opening available up to 5000 mm. Models suitable for door weight ranging from 40 kg up to 350 kg each leaf
- Intelligent microprocessor based control unit provides a wide range of functions like manual / automatic, one / two ways, total / partial opening, night mode
- Traction by means of synthetic electro conducting toothed belt ensures silent operation and built-in anti-crush device with encoder
- Self diagnosis. Wide range of infrared and microwave sensors and various other accessories like pneumatic elbow push buttons, floor mats, table top push button panels
- Provision for breakaway anti panic system, backup battery, electromechanical lock, photocells for safety
- Provision for interfacing with P.C. for management and control of multiple installations
- Possibility of installing carriages with fire-proof brass wheels that
- Enable emergency sliding of the door



Gates >> Swing Gates

Swing gates are fabricated to provide security, convenience and protection against unauthorized intrusion. Aesthetically fabricated these gates are made with square pipes encased in a pipe frame customized to suit the client's requirements and are finished with spray painting.

GATES MOUNTED ON PIVOTS WITH BALL BEARINGS

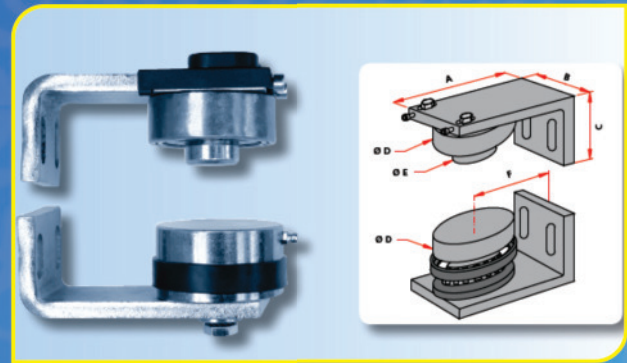

Sliding Gate Hardware

- Wide range of models for gate span from 3 m to 10 m
- Models available with frequent, heavy and intensive duty rating
- Electromechanical actuators ensures highly maintenance free and silent operation
- Provision for manual operation in case of power failure
- Model with articulated arms for gates not perfectly vertical and/or with wide pillars, underground operators are also available for ornamental gates
- Built-in anti-crushing safety
- Advance electronic control unit permits operation time adjustment, partial opening, automatic closing, step by step control, stop safety, reverse safety & many more such operations.



Provision of goods lift in a distribution ware house

From our extensive range of industrial products, we manufacture, export and supply supreme quality Industrial Lift. For the manufacturing of this lift, our dexterous team of professionals use premium grade components and pioneering technology in sync with the defined international standards. Provided lift is used for carrying goods & heavy materials and installed in various industrial buildings. Besides, the offered Industrial Lift is available in varied capacities and specifications at reasonable rates.

Features:

- Long service life
- Highly spacious
- Perfect finish
- Low energy consumption

FABRICATION WORK

Fabrication Service

We hold immense expertise in catering to the ever-changing demands of the customers by undertaking unparalleled Fabrication Service. The services offered by us are executed by a deft team of expert professionals who employ modern techniques & genuine components during the execution process. Further, these professionals assure that the services are rendered in strict accordance with the universally accepted quality norms & standards fabrication Service



Belt Conveyor

Belt Conveyor offered are well recognized for their precision engineering and construction standards and comprises two or more pulleys having continuous loop of material which rotates above them. Here, we can deliver these belt conveyors in different sizes where the end finish depends upon the weight of material as well as distance up to which these need to be carried. Some of the industry sectors where these are used in include Cement industries, Steel industries, Sugar industries, Mining industries, Construction industries, Paper and Pulp industries and others.

Our range finds applications in the following industries:

- Cement industries
- Steel industries
- Sugar industries
- Mining industries
- Construction industries
- Paper and Pulp industries
- Pharma industries
- Other light and heavy engineering industries.

Type off conveyor

- Belt Conveyor
- Chain Conveyor
- Assembly Line Conveyor
- Roller Conveyor
- Slat Conveyor
- Belt Conveyor for Food Industry

Scissor Lift for Lifting Goods

We are a major manufacturer and supplier of scissor lifts .We provide an inclusive assortment of Scissor Lift Table which are designed and manufactured by the high grade raw material. Used for lifting various heavy goods.

Features:

- High Durability
- Movable
- Completely Tested
- Easy to use
- Affordable Prices
- High lifting capacity



Office Address: Bhanudash Nagar Near Of Akashwani In front Of Matamandir Aurangabad-43100 1(M.S)

Work Address: Pratab chock near C-285 M.I.D.C Waluj Aurangabad-431136 (M.S)

Cont. person : Er.Deepak Rajpoot (D.M.E, B.E Mech.) **Mobile:** 08087335001

E-mail: mayurengg.automation@gmail.com **URL:** www.mayurengineering.weebly.com